

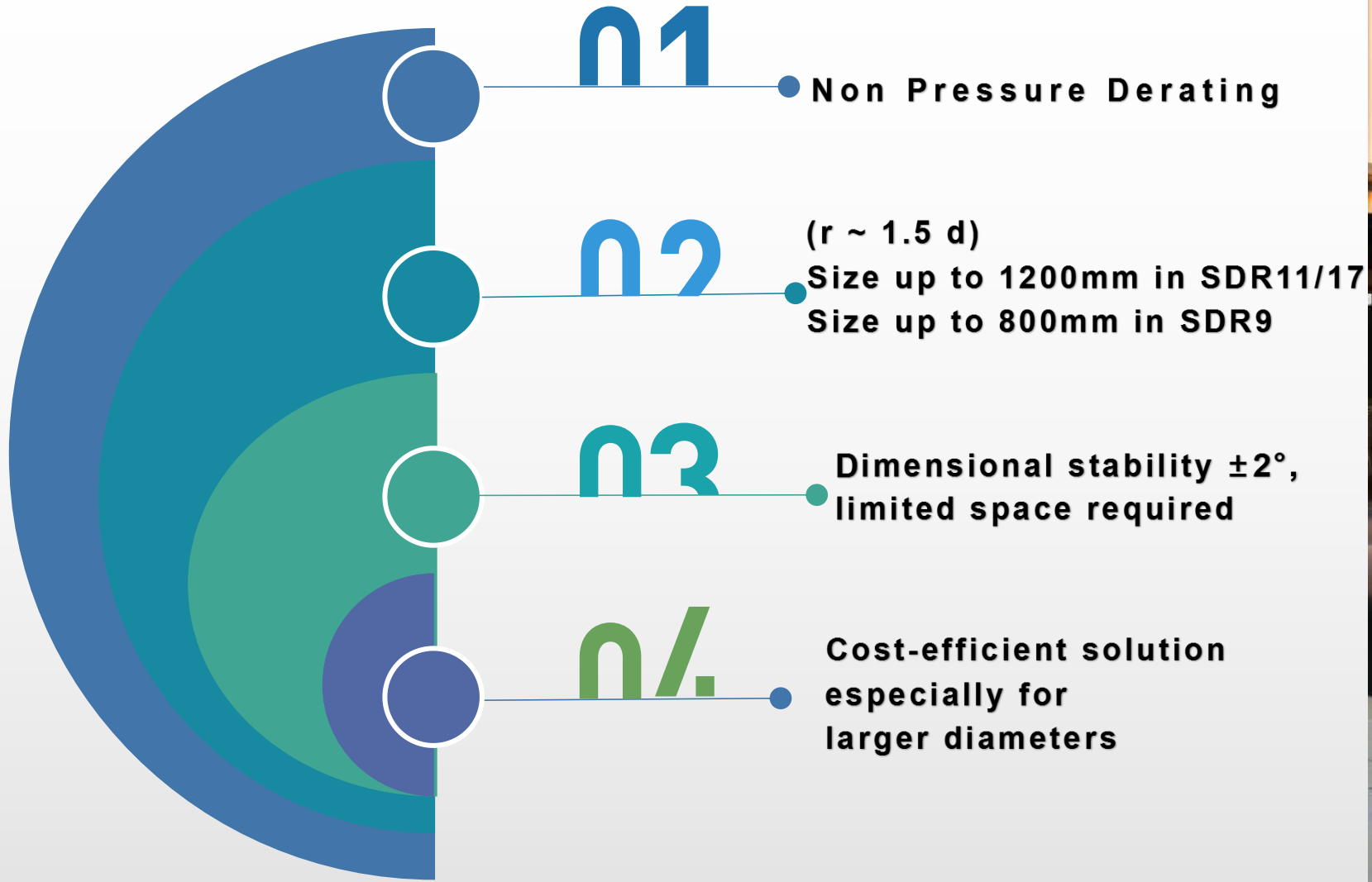

SWEEP BEND SOLUTION





How Smart Joint Sweep Bend Made? 90° Sweep Bend

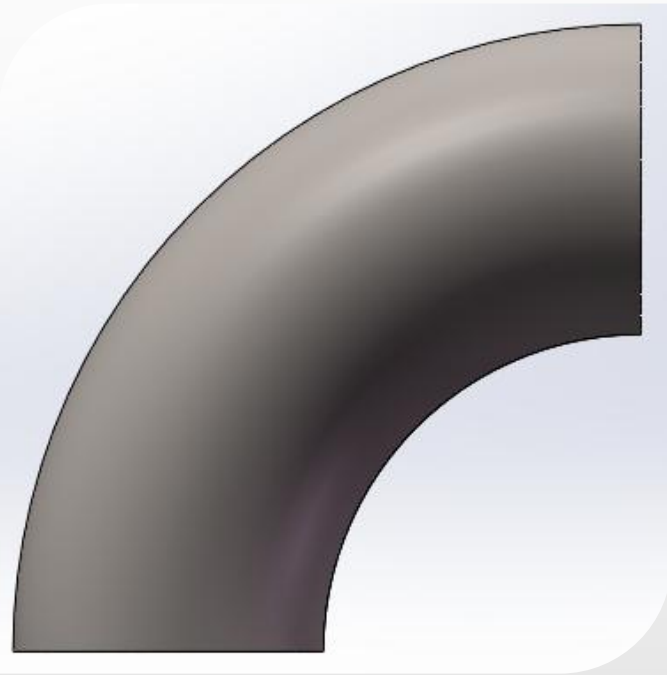

Initial 90° Bend

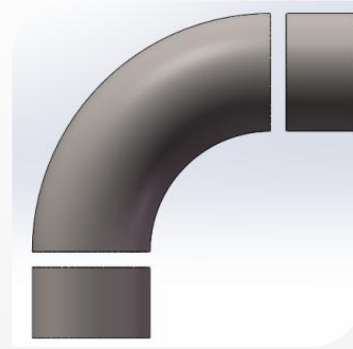

With extension
by fabrication, final tubular
length between 250mm-
300mm, Internal Bead
Removed.

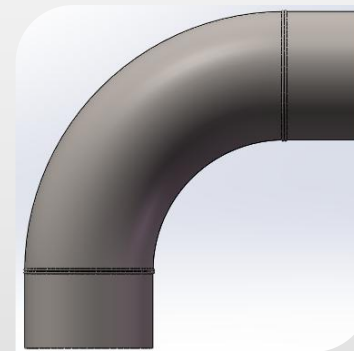

Butt Fusion Joint Fusion
Process Recorded by Data
Logger can be supplied.

45° Sweep Bend

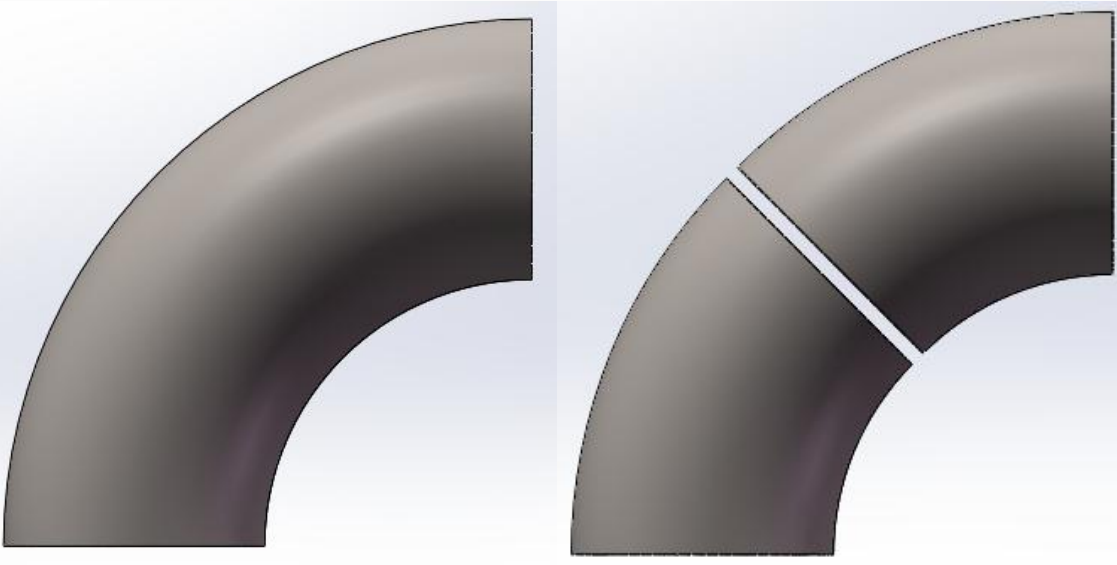

Initial 90° Bend cut into 2 pcs of 45° bends

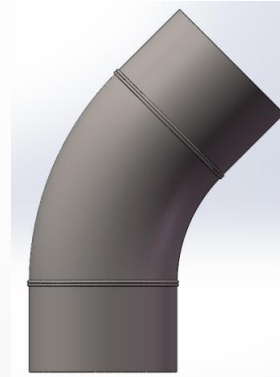
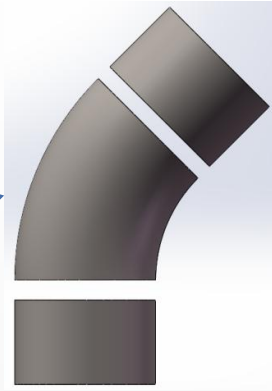

With extension
by fabrication, final tubular
length between 250mm-
300mm, Internal Bead
Removed.

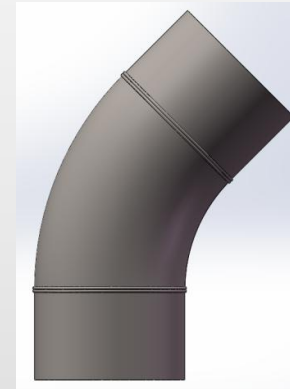
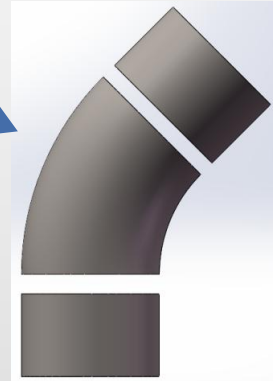

Butt Fusion Joint Fusion
Process Recorded by Data
Logger can be supplied.

30° & 60° Sweep Bend

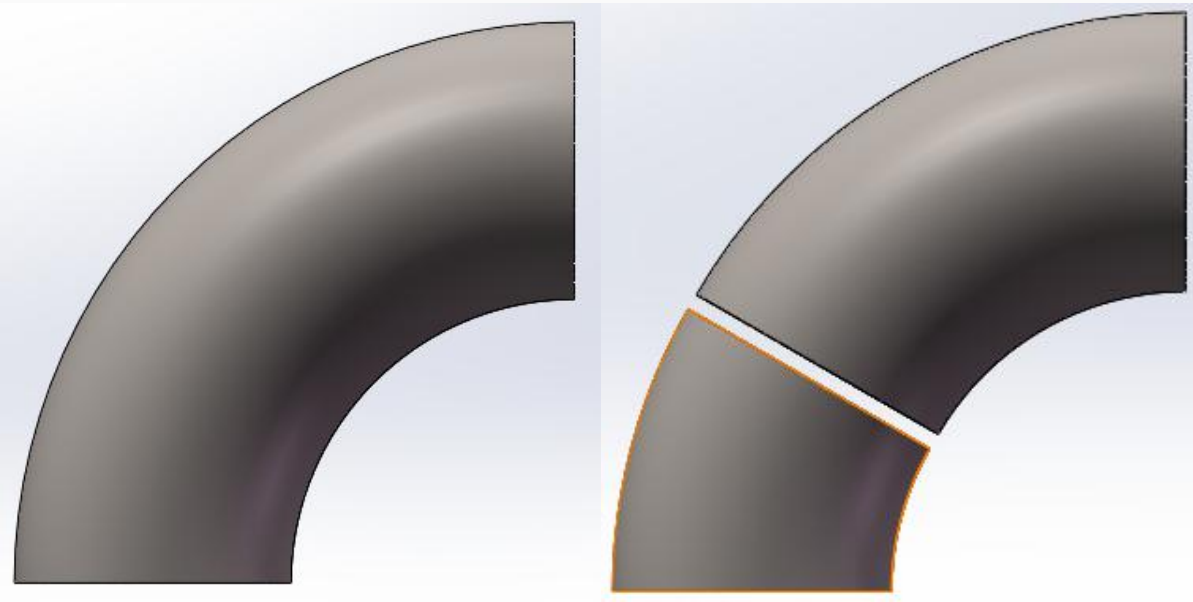

Initial 90° Bend cut into 1 pc of 30° bend and 1 pc of 60° bend

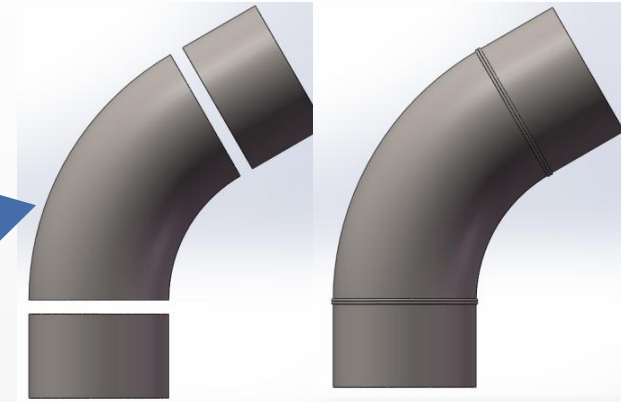

With extension by fabrication, final tubular length between 250mm-300mm, Internal Bead Removed.

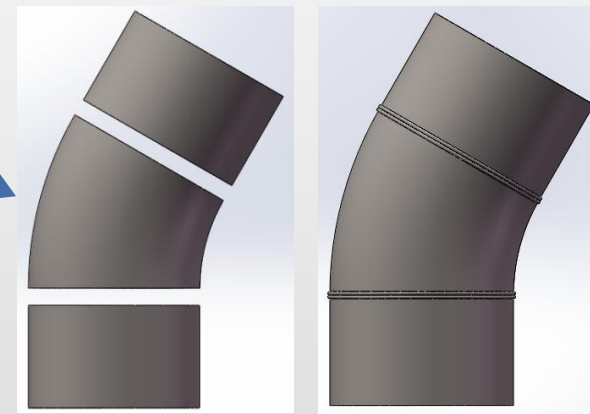

Butt Fusion Joint Fusion Process Recorded by Data Logger can be supplied.

Any Cut for Any Degree

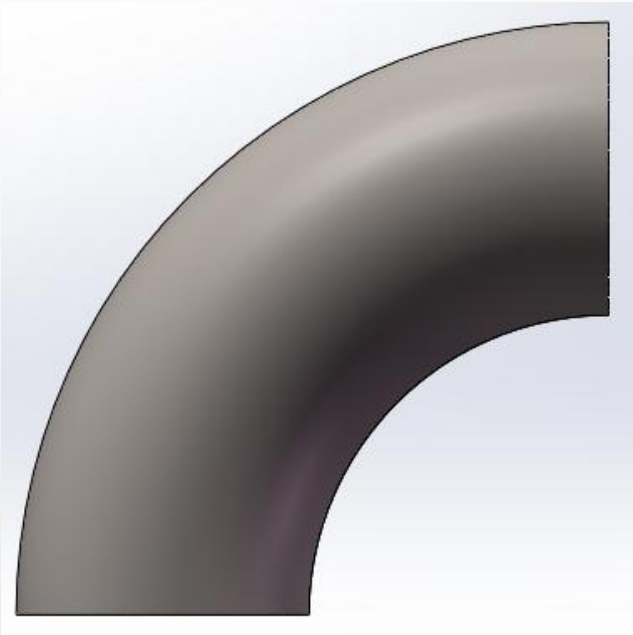

Initial 90° Bend

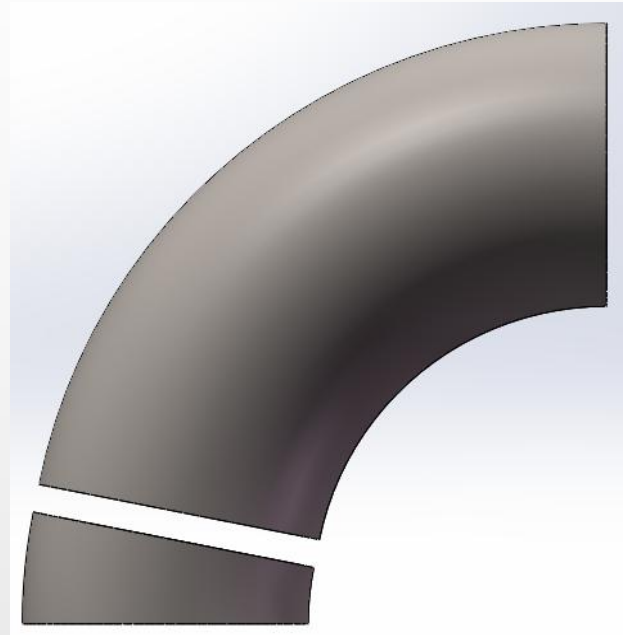

Any degree cut

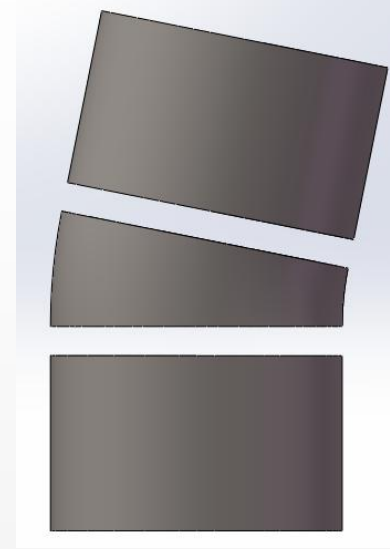

With extension
by fabrication, final tubular
length between 250mm-
300mm, Internal Bead
Removed.

Butt Fusion Joint Fusion
Process Recorded by Data
Logger can be supplied.

